



Product Specifications



Product description

**Bau Cosmo E  
Touchless Electronic Tap**

Turns water on and off automatically when infrared sensor detects hand motion

Touchless, hands-free operation provides safer, more hygienic experience

Water will run for 60 maximum of 60 seconds per cycle  
Separate inner water ways within the tap to prevent lead and nickle contamination for clean drinking water

**Grohe Long-life finish**

Battery powered, includes CR-P2 lithium battery with 7-year life (expected) based on 150 uses per day

Optional remote control accessory (36407) sold separately

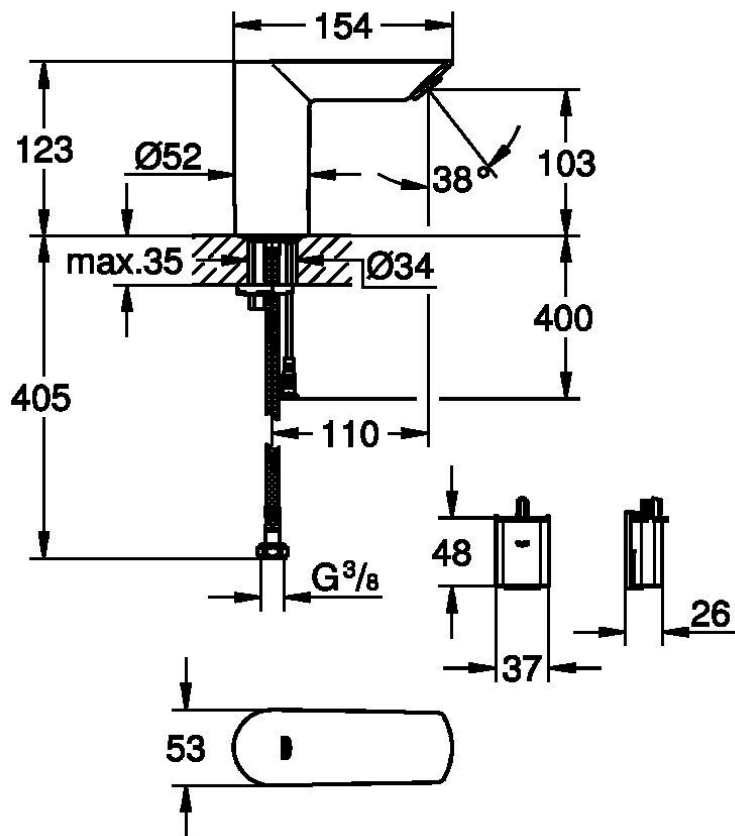

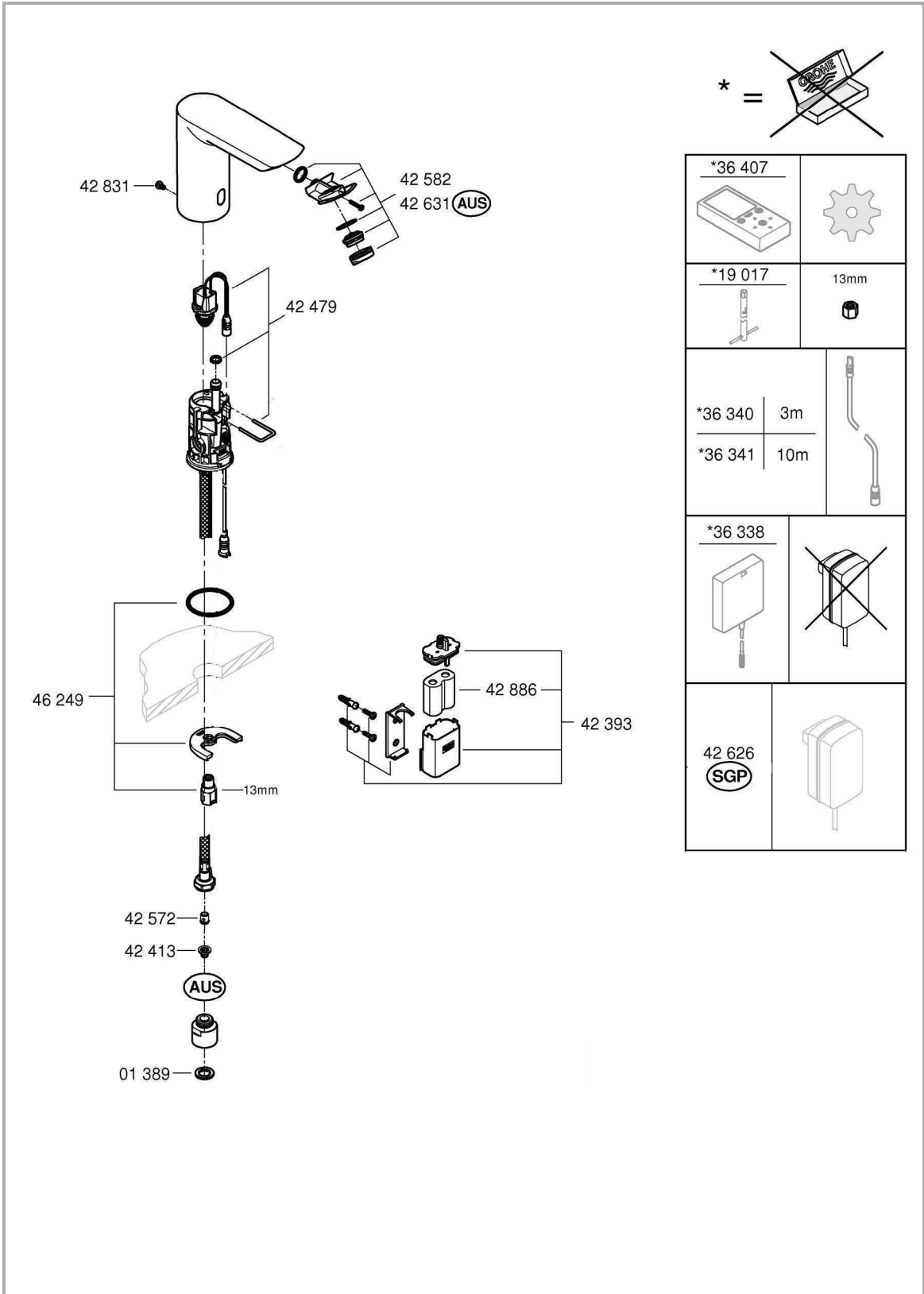

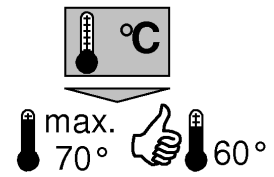
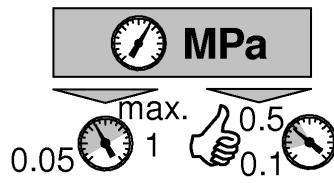

DIN 1988  
DIN EN 806

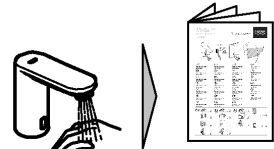
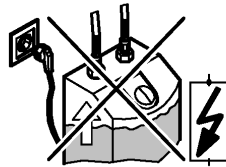
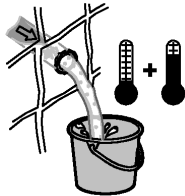

99.0438.XXX

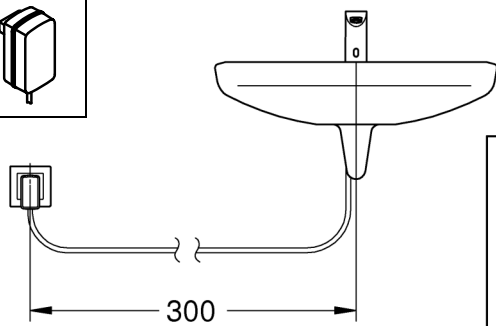
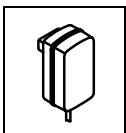
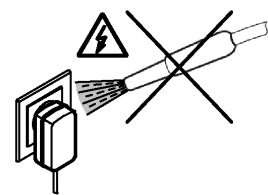
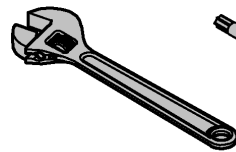
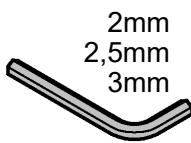

	*36 340 3m
	*36 341 10m

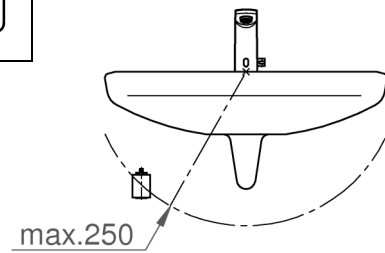
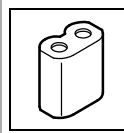

1

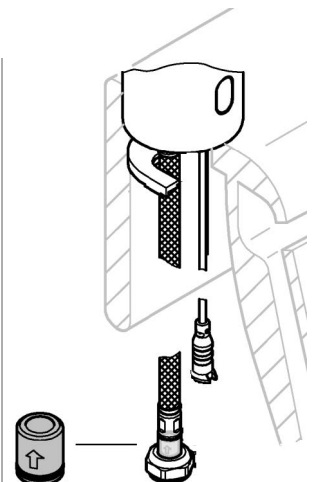
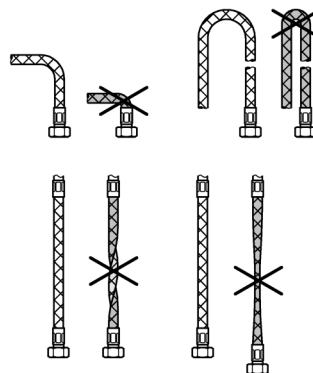
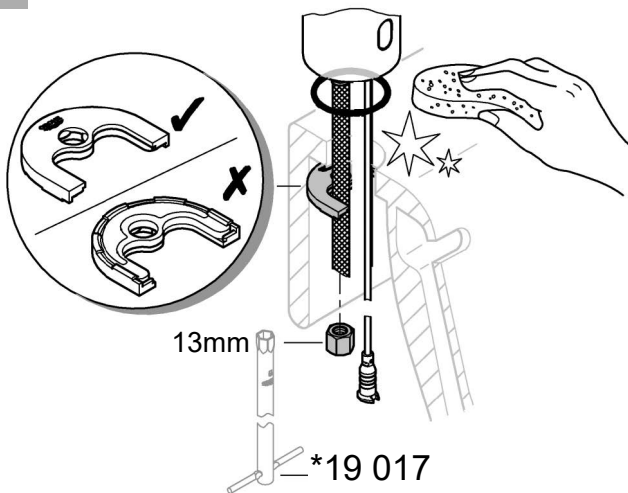

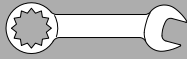

2a

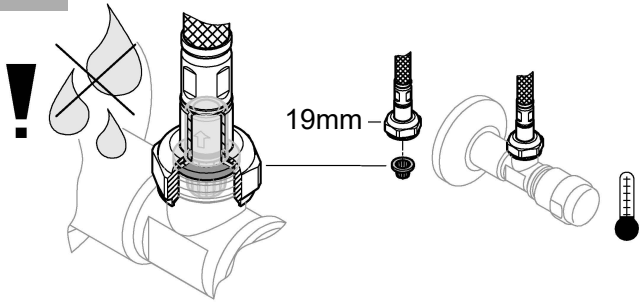

2b

AUS

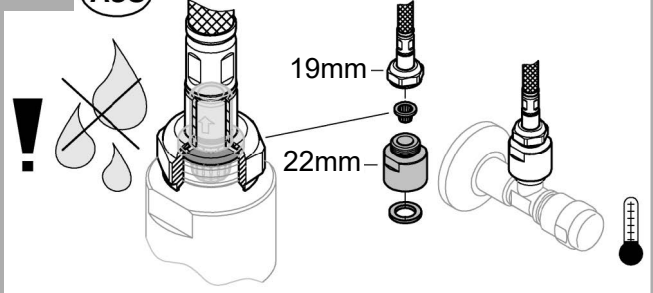

3a

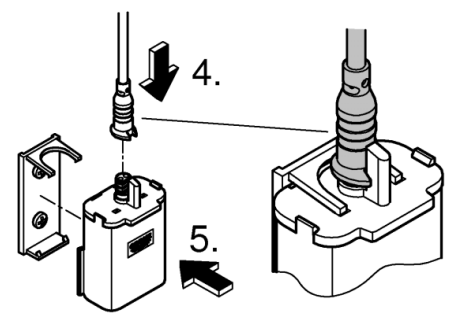
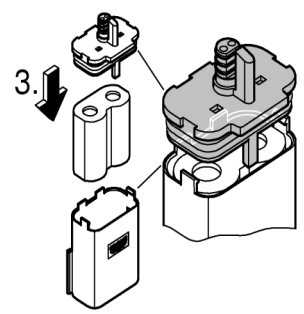
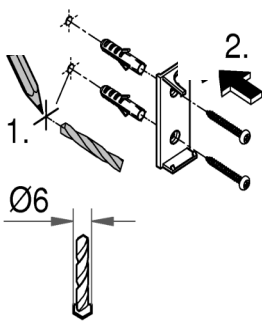



1

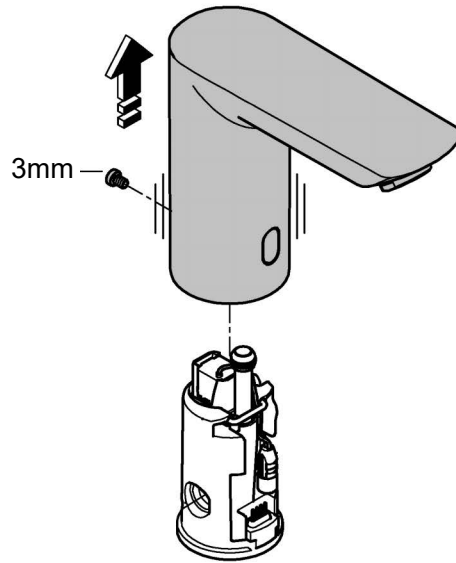
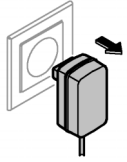

2

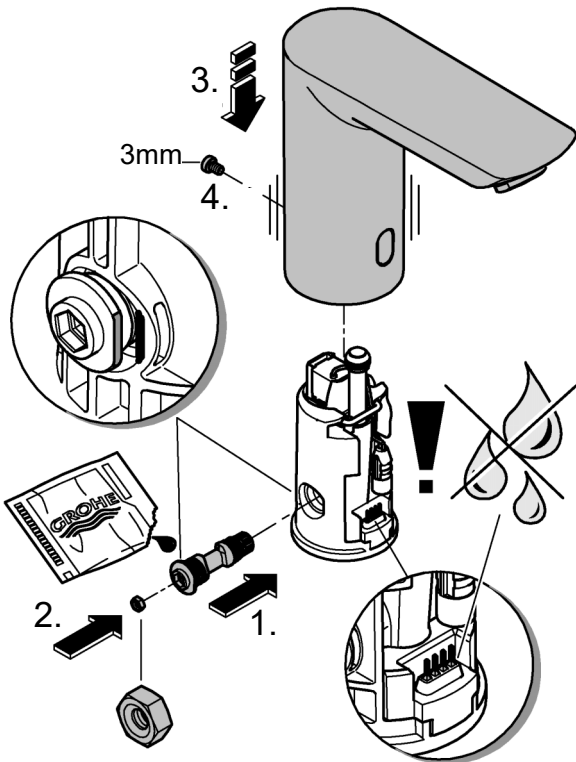

3

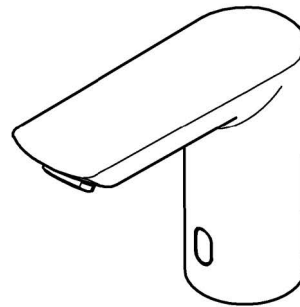

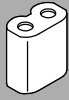

SERVICE

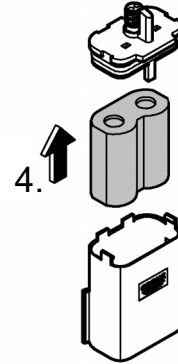
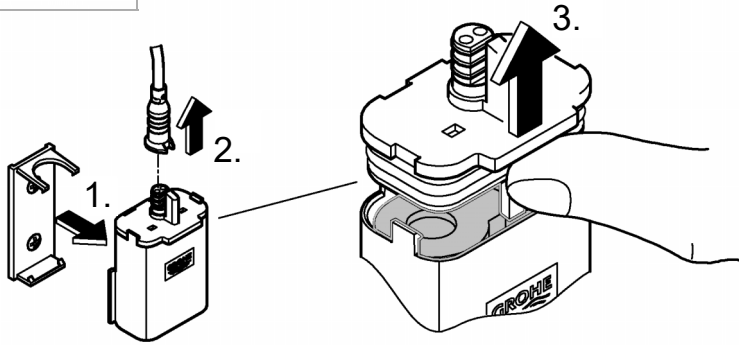

SERVICE

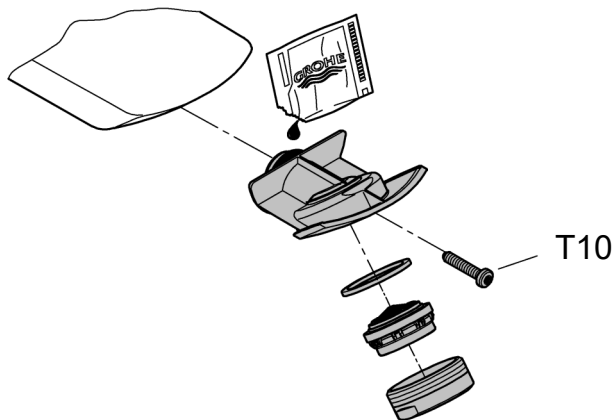
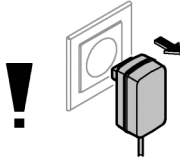

**Safety notes**



Prevent danger resulting from damaged voltage supply cables. If damaged, the voltage supply cable must be replaced by the manufacturer or his customer service department or an equally qualified person.

- Installation is only possible in frost-free rooms.
- The plug-in voltage supply is only suitable for indoor use.
- The plug-in connectors must **not** be directly or indirectly sprayed with water when cleaning.
- The voltage supply must be separately switchable.
- Use **only genuine replacement parts and accessories**. The use of other parts will result in voiding of the warranty and the CE identification, and could lead to injuries.

**Technical data**

- Automatic safety shut-off: 60 s (6 - 420 s adjustable)
- Run-on time (0 - 19 s adjustable): 1 s
- Reception range according to Kodak Gray Card, grey side, 8x10", landscape (7 - 20 cm adjustable): 12 cm
- Type of fitting protection: IP 59K

Thermal disinfection possible.

**Fitting with switched-mode power supply:**

- Voltage supply: 100-240 V AC 50-60 Hz/6.75 V DC
- Power consumption: 2.4 W

**Fitting with battery:**

- Voltage supply: 6V lithium battery type CR-P2

**Electrical test data**

- Software class A
- Contamination class 2
- Rated surge voltage 2500 V

- Temperature of ball impact test 100 °C

The test for electromagnetic compatibility (interference emission test) was performed at the rated voltage and rated current.

If static pressures exceed 0.5 MPa, a pressure-reducing valve must be installed.

Avoid major pressure differences between hot and cold water supply!



**Operation and settings,**

see technical product information 99.0438.xxx

**Activating setting mode**

Disconnect the power supply to the electronics and reconnect after 10 s.

The indicator lamp in the sensor system illuminates in setting mode when the detection zone of the fitting is reached by an approaching user.

Setting mode is automatically terminated after 3 minutes.



**Maintenance**

Batteries which are almost discharged are displayed by a flashing indicator lamp in the sensor system.



**Replacement parts**

(\* = special accessories)

**Care**

For directions on the care of this fitting, please refer to the accompanying Care Instructions.

This product must be installed in conformance with local codes e.g. AS/NZS 3500 series of standard!

**Fault / Cause / Remedy**

Fault	Cause	Remedy
<b>Water not flowing</b>	<ul style="list-style-type: none"> <li>• Filter upstream of solenoid valve blocked</li> <li>• Solenoid valve defective</li> <li>• Plug-in connector without contact</li> <li>• No voltage                             <ul style="list-style-type: none"> <li>- Battery discharged (indicator lamp lights up continuously)</li> <li>- Power supply unit defective</li> </ul> </li> </ul>	<ul style="list-style-type: none"> <li>- Clean filter</li> <li>- Replace solenoid valve</li> <li>- Check plug-in connector electronics and solenoid valve</li> <li>- Replace battery</li> <li>- Replace power supply unit</li> </ul>
<b>Undesired water flow</b>	<ul style="list-style-type: none"> <li>• Sensor system detection zone set too high for local conditions</li> <li>• Automatic flushing activated</li> <li>• Solenoid valve defective</li> </ul>	<ul style="list-style-type: none"> <li>- Reduce range using remote control (special accessory, prod. no.: 36 407) / app</li> <li>- Wait 1 - 10 minutes</li> <li>- Replace solenoid valve</li> </ul>
<b>Flow rate too low</b>	<ul style="list-style-type: none"> <li>• Mousseur dirty</li> <li>• Filter upstream of solenoid valve dirty</li> <li>• Filters in connection hose dirty</li> <li>• Non-return valve defective</li> </ul>	<ul style="list-style-type: none"> <li>- Clean or replace mousseur</li> <li>- Clean filter</li> <li>- Clean or replace filters</li> <li>- Replace the non-return valve</li> </ul>



48166000

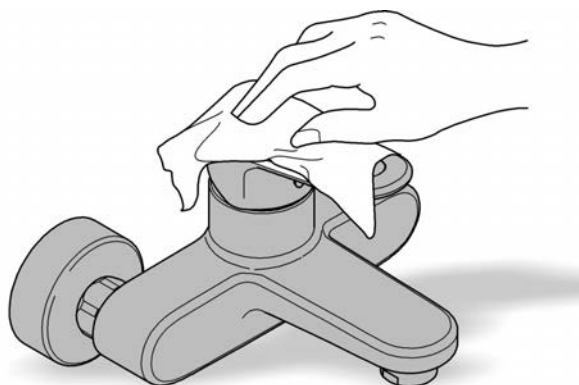
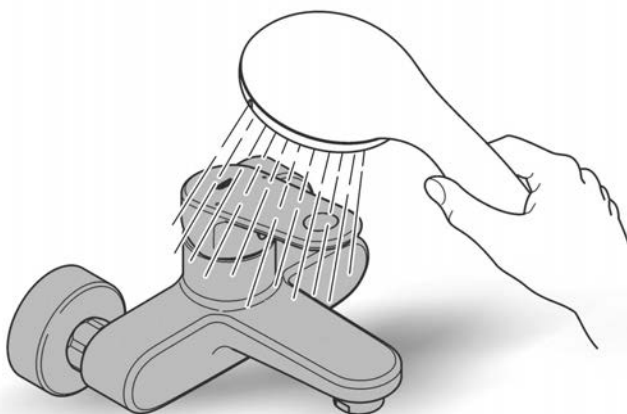
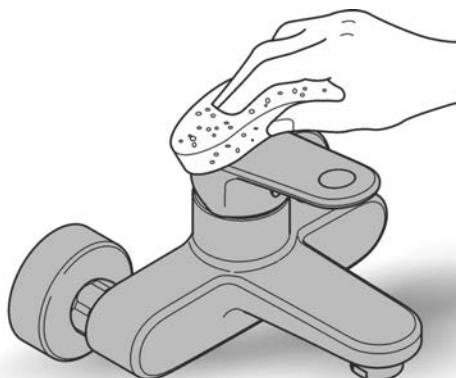

SpeedClean





Pure Freude  
an Wasser

**GROHE**  

**D**

+49 571 3989 333  
impressum@grohe.de

**A**

+43 1 68060  
info-at@grohe.com

**AUS**

+1300 054 945  
grohe\_australia@lixil.com

**B**

+32 16 230660  
info.be@grohe.com

**BG**

+359 2 9719959  
grohe-bulgaria@grohe.com

**CAU**

+99 412 497 09 74  
info-az@grohe.com

**CDN**

+1 888 6447643  
info@grohe.ca

**CH**

+41 448777300  
info@grohe.ch

**CN**

+86 21 63758878

**CY**

+357 22 465200  
info@grome.com

**CZ**

+420 277 004 190  
grohe-cz@grohe.com

**DK**

+45 44 656800  
grohe@grohe.dk

**E**

+34 93 3368850  
grohe@grohe.es

**EST**

+372 6616354  
grohe@grohe.ee

**F**

+33 1 49972900  
marketing-fr@grohe.com

**FIN**

+358 10 8201100  
teknocalor@teknocalor.fi

**GB**

+44 871 200 3414  
info-uk@grohe.com

**GR**

+30 210 2712908  
nsapountzis@ath.forthnet.gr

**H**

+36 1 2388045  
info-hu@grohe.com

**HK**

+852 2969 7067  
info@grohe.hk

**I**

+39 2 959401  
info-it@grohe.com

**IND**

+91 124 4933000  
customercare.in@grohe.com

**IS**

+354 515 4000  
jonst@byko.is

**J**

+81 3 32989730  
info@grohe.co.jp

**KZ**

+7 727 311 07 39  
info-cac@grohe.com

**LT**

+372 6616354  
grohe@grohe.ee

**LV**

+372 6616354  
grohe@grohe.ee

**MAL**

+1 800 80 6570  
info-singapore@grohe.com

**N**

+47 22 072070  
grohe@grohe.no

**NL**

+31 79 3680133  
vragen-nl@grohe.com

**NZ**

+09 415 6000  
sales@monacocorp.co.nz

**P**

+351 234 529620  
commercial-pt@grohe.com

**PL**

+48 22 5432640  
biuro@grohe.com.pl

**RI**

+62 21 2358 4751  
info-singapore@grohe.com

**RO**

+40 21 2125050  
info-ro@grohe.com

**ROK**

+82 2 559 0790  
info-singapore@grohe.com

**RP**

+63 2 8041617

**RUS**

+7 495 9819510  
info@grohe.ru

**S**

+46 771 141314  
grohe@grohe.se

**SGP**

+65 6 7385585  
info-singapore@grohe.com

**SK**

+420 277 004 190  
grohe-cz@grohe.com

**T**

+66 2610 3685  
info-singapore@grohe.com

**TR**

+90 216 441 23 70  
GroheTurkey@grome.com

**UA**

+38 44 5375273  
info-ua@grohe.com

**USA**

+1 800 4447643  
us-customerservice@grohe.com

**VN**

+84 8 5413 6840  
info-singapore@grohe.com

**AL** **BIH** **HR** **KS**

**ME** **MK** **SLO** **SRB**

+385 1 2911470  
adria-hr@grohe.com

**Eastern Mediterranean,  
Middle East - Africa  
Area Sales Office:**

+357 22 465200  
info@grome.com

**IR** **OM** **UAE** **YEM**

+971 4 3318070  
grohedubai@grome.com

**Far East Area Sales Office:**

+65 6311 3600  
info@grohe.com.sg