

CLU31111CAAULW00

500 Wall basin

Recommended use Domestic, hotel and commercial

KEY SPECIFICATIONS

- Finish: White
- Integral overflow: Yes
- Fixing: Fixing bolts supplied
- Tap hole: 1TH
- Plug and waste: 32 x 40mm waste (not included)
- Template: NA
- Warranty: 10 years

FEATURES

- Material: Vitreous china
- Overall dimensions (mm): L500x W425 x H210

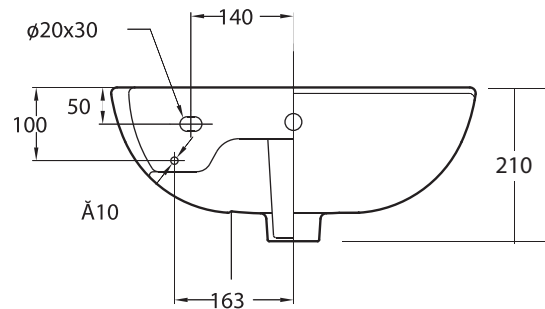
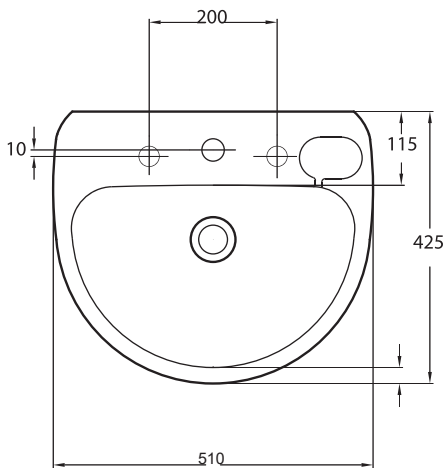

SHIPPING WEIGHT

- Gross Weight: 7.3kg