

CCASF412-100410N1

## 550mm Vessel

### Recommended use

Domestic, hotel and commercial

### KEY SPECIFICATIONS

- Finish: White
- Integral overflow: No
- Fixing: Sealed to bench top
- Tap hole: NTH
- Plug and waste: Drainage with ceramic cover (included)
- Template: Supplied with product
- Warranty: 10 years

### FEATURES

- Material: Fine Fire Clay
- Overall dimensions (mm): L550xW380xH110mm
- Design: Thin edge

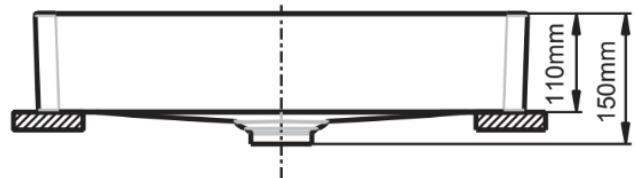
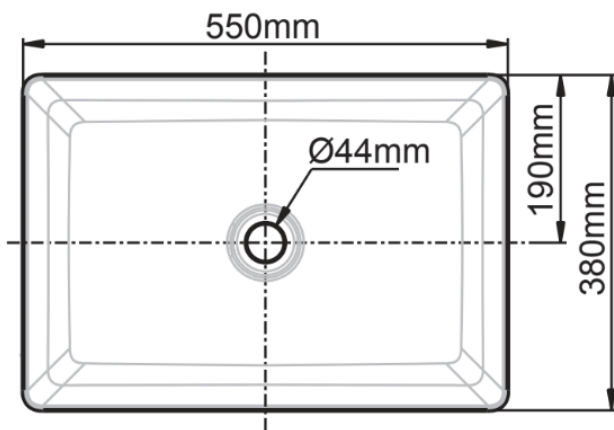

### SHIPPING WEIGHT

- Gross Weight: 6kg